

BAL SEAL® SEALS IN ULTRASONIC EQUIPMENT

Ultrasound is a high-frequency sound pressure wave transmitted and received through a rotating transducer. The transducer is submerged in a viscous fluid, which acts as a wave medium.

The Bal Seal® seal surrounds the rotating shaft tightly and controls the leakage into the internal circuitry. Bal Seal seals have excellent chemical compatibility, low friction, and reliable sealing performance in these types of applications.

Operating Parameters

Pressure:	5 psi (0.4 kg/cm ²)
Speed:	5,000 rpm
Temperature:	70 °F to 120 °F (21 °C to 49 °C)
Media:	Low-viscosity oil
Additional:	Low friction and sealing performance reliability

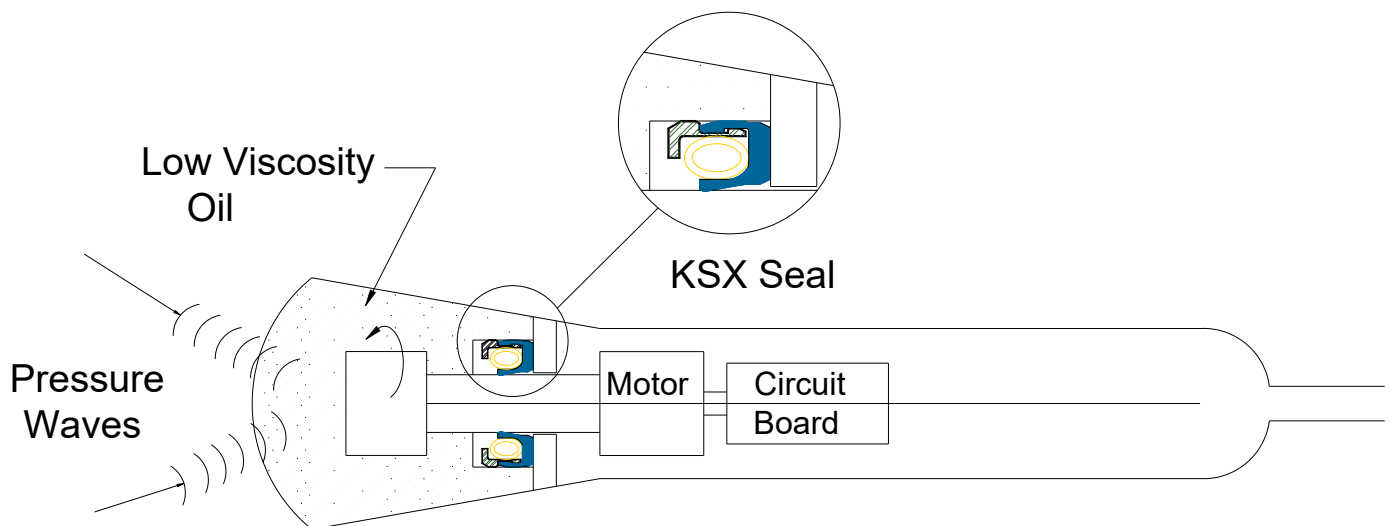

Seal Selection: KSX

Features:

- Bal Seal® series KSX is selected for its excellent press-in metal locking ring retention system
- Excellent sealing of the low-viscosity oil within the reservoir
- Low-friction seal design minimizes frictional heat buildup
- Bal Spring® canted coil spring energizer provides near-constant energizing force for long seal life
- Filled PTFE seal materials have excellent wear resistance and are FDA-compatible

For more information and technical assistance, contact a technical sales representative.

PATENTS: The items described in this page include products that are the subject of issued United States and foreign patents or products where patents are pending, including the following: Patents 6,641,141 B2; 7,210,398 B2; 6,161,838; 5,992,856; 5,134,244

U.S. Address: 19650 Pauling Foothill Ranch, CA 92610-2610 • Phone: (949) 460-2100 • Fax: (949) 460-2300

BV Address: VIDA Building, First Floor • Kabelweg 57 • 1014 BA Amsterdam • The Netherlands • Phone: 31 20 638 65 23 • Fax: 31 20 625 60 18

Bal Seal Engineering is certified to **ISO 9001** | www.balseal.com