

BAL SEAL® SEALS IN CENTRIFUGAL SUPERCHARGER

Superchargers are high-speed, low-pressure units that increase engine efficiency by boosting air pressure into the engines intake manifold.

Bal Seal® series KPx consists of a PTFE memory lip locking metal ring assembly design to operate under such conditions. The unique locking metal ring secures the seal assembly firmly into the housing gland with memory lip providing low-friction sealing on the shaft.

The KPx lip design is a proprietary process of Bal Seal Engineering, Inc. that has memory permanently placed in the seal material; it creates a low-friction contact stress, which provides longer seal life.

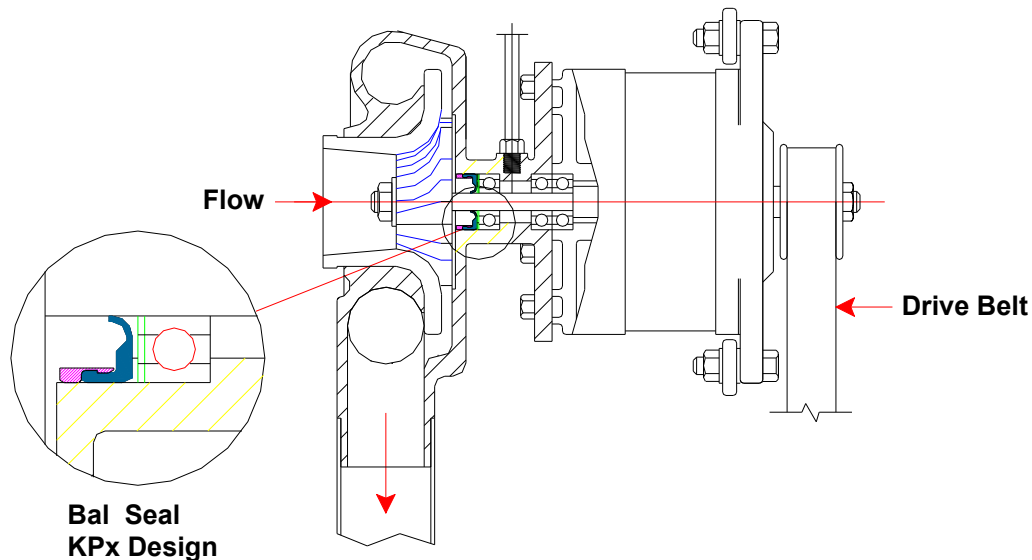

Operating Parameters

| | |
|--------------|--|
| Pressure: | Up to 15 psi (1.1 kg/cm ²) |
| Speed: | 7500 fpm |
| Temperature: | -65F to 250F (21C to 121C) |
| Media: | Fuel vapor, bearing lubrication |
| Additional: | Low friction |

Seal Selection: KPx series

Features:

- Bal Seal series KPx have an excellent press-in metal locking ring retention system
- Unique seal geometry provides superior sealing performance at varying speeds
- Bal Seal seals provide low friction to sustain efficiency
- Outstanding wear-resistant, filled, PTFE seal materials ensure long life and reduced maintenance cost

For more information and technical assistance, consult the Technical Sales Department.

PATENTS: The items described in this page include products that are the subject of issued United States and foreign patents or products where patents are pending, including the following: Patents 6,641,141 B2; 7,210,398 B2; 6,161,838; 5,992,856; 5,134,244

U.S. Address: 19650 Pauling Foothill Ranch, CA 92610-2610 • Phone: (949) 460-2100 • Fax: (949) 460-2300

BV Address: VIDA Building, First Floor • Kabelweg 57 • 1014 BA Amsterdam • The Netherlands • Phone: 31 20 638 65 23 • Fax: 31 20 625 60 18