

## BAL SEAL® SEALS IN PRESSURE-RELIEF VALVES

Relief valves are used in hydraulic circuits that incorporate a positive displacement pump, such as a gear, vane, or piston pump. Reliability and performance are critical because these applications are connected across a pump pressure line and act as a safety valve to protect the pump.

Bal Seal® seals have repeatedly proven their performance in these types of critical applications. Bal Seal Engineering, Inc. continues to improve seal designs and material technology for improved sealing, lower stress concentration and longer seal life.

In addition, Bal Seal high-performance PTFE blends, ultra-high molecular weight polyethylene, and other materials are highly reliable in applications with abrasive environments.

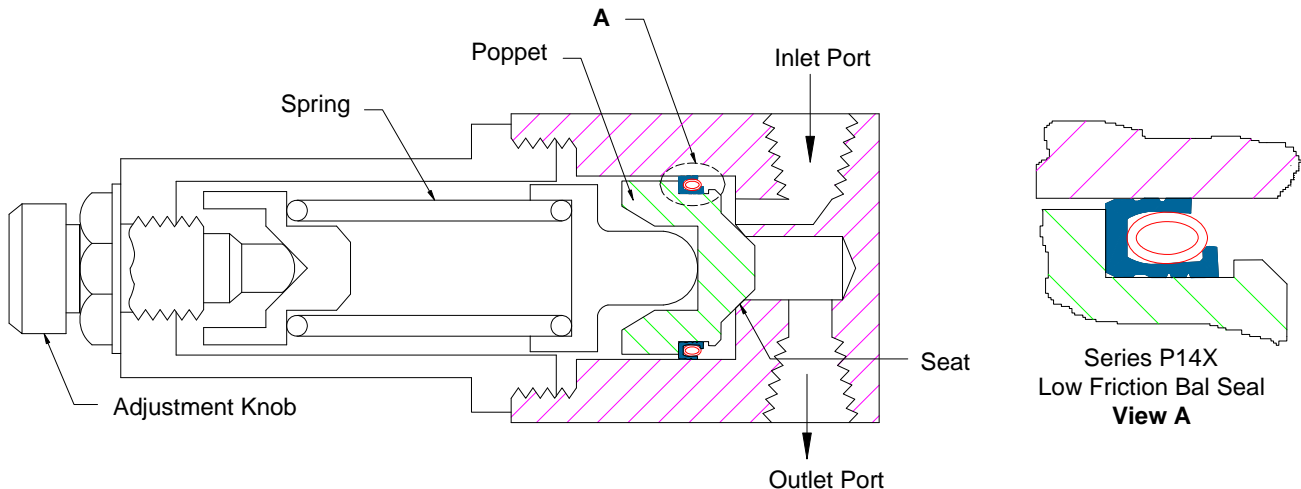

### Operating Parameters

Sealing pressure:	3,000 psi (211 kg/cm <sup>2</sup> )
Typical speed:	Slow
Temperature:	- 70°F to 250°F ( - 57°C to 121°C)
Media:	Hydraulic oil
Additional:	Reliability, sealing ability and low friction

**Seal Selection:** P14X series

### Features:

- The P14X series shot-lip seals are specifically designed to mount into low-step piston grooves, which saves the customer manufacturing and assembly costs.
- Short-lip seals have outside and inside diameter sealing grooves that retain lubricants and act as additional sealing features that continue to work as the seal wears.
- Patented, canted-coil spring energizer provides near-constant force over the spring deflection range, ensuring low frictional drag, consistent sealing and long life.
- Bal Seal Engineering provides filled PTFE seal materials with excellent wear resistance and chemical compatibility as well as other high-temperature engineered plastic compounds that are reliable in long-term applications.

For more information and technical assistance, consult the Technical Sales Department.

PATENTS: The items described in this page include products that are the subject of issued United States and foreign patents or products where patents are pending, including the following: Patents 6,641,141 B2; 7,210,398 B2; 6,161,838; 5,992,856; 5,134,244

U.S. Address 19650 Pauling Foothill Ranch, CA 92610-2610 • Phone: (949) 460-2100 • Fax: (949) 460-2300  
BV Address: Jollemanhof 16, 5th floor • 1019 GW Amsterdam • The Netherlands • Phone: 31 20 638 65 23 • Fax: 31 20 625 60 18  
Rev.D 8-30-07 (11-188) [www.balseal.com](http://www.balseal.com)

