

BAL SEAL® SEALS IN ROTARY GEAR PUMPS

Rotary gear pumps are useful for fluid transfer, power units and handling liquids, such as petrochemical, food and medical products. The pump is fitted with a rotating gear or impeller that draws fluid into its chamber and through an inlet port. Then, as the gear rotates, pressure builds up in the chamber and pushes fluid through the outlet port.

Bal Seal® seals provide reliable sealing between the pressurized fluid and the environment. A KS series Bal Seal seal (shown below) closes the uncaptivated rotating shaft for low-pressure applications. A fully retained seal provides greater pressure.

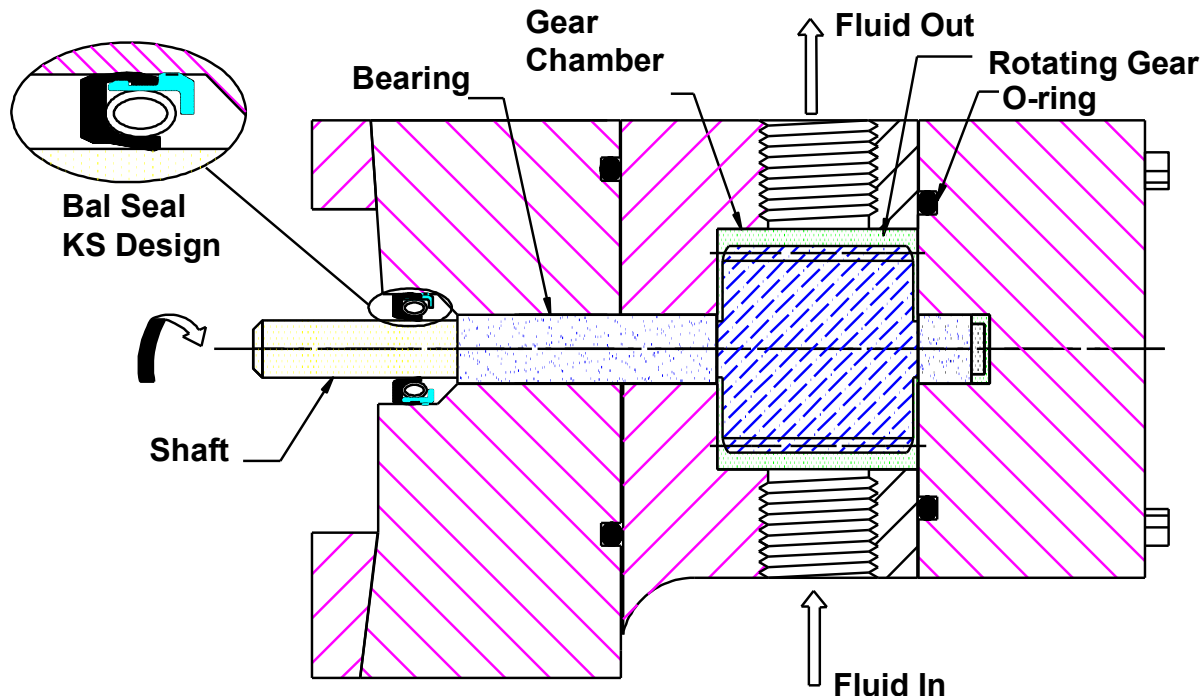

Operating Parameters

Pressure:	Atmospheric to 15 psi (1.1 kg/cm ²)
Speed:	1,500 rpm
Temperature:	65F to 300F (-54C to 149C)
Media:	Food and medical products, hydrocarbons, petrochemicals, and water-based fluids
Additional:	Low friction and good sealing ability

Seal Selection: KS series

Features and Benefits:

- KS series Bal Seal seals have excellent press-in metal locking ring retention systems.
- Excellent sealing performance contains the media from the environment.
- Bal Seal seals provide low friction to sustain pump efficiency.
- Excellent wear-resistant jacket materials ensure long operational pump life and reduced maintenance cost.
- Patented, canted-coil spring energizers provide near-constant force for long seal life.
- Filled PTFE seal materials operate unlubricated and are FDA compatible.*

For more information and technical assistance, consult the Technical Sales Department.

PATENTS: The items described in this page include products that are the subject of issued United States and foreign patents or products where patents are pending, including the following: Patents 6,641,141 B2; 7,210,398 B2; 6,161,838; 5,992,856; 5,134,244
U.S. Address 19650 Pauling Foothill Ranch, CA 92610-2610 • Phone: (949) 460-2100 • Fax: (949) 460-2300

BV Address: Jollemanhof 16, • 1019 GW Amsterdam • The Netherlands • Phone: 31 20 638 65 23 • Fax: 31 20 625 60 18

Rev.B 10-18-07 (11-270)

Bal Seal Engineering, Inc. is certified to ISO 9001 | www.balseal.com